

INSTALLATION INSTRUCTIONS

EQUIPMENT REQUIRED: CHISEL

WIRING ACCESS LOCATION: SUV3

DRILL BITS:

HITCH REQUIRES 5/8" PIN AND CLIP IF STABILIZING PIN IS NOT INSTALLED.

WRENCHES: (TIGHTEN ALL FASTENERS WITH TORQUE WRENCH) 18mm, 3/4, 13/16, 7/8

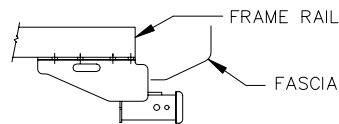

HITCH SHOWN IN PROPER POSITION

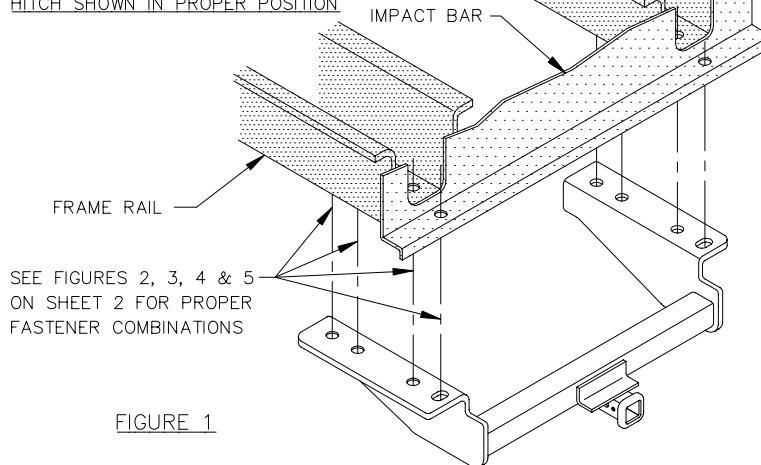

FIGURE 1

VEHICLE	HITCH NO.
JEEP CHEROKEE	75054
JEEP WAGONEER (DOWNSIZED MODEL)	33002

DO NOT EXCEED LOWER OF
TOWING VEHICLE MFR'S RATINGS OR

HITCH TYPE	MAX GROSS TRLR WT(LB)	MAX TONGUE WT(LB)
WEIGHT DISTRIBUTING	5500	550
WEIGHT CARRYING BALL MOUNT	3500	350

OPTIONAL LOCKING STABILIZING PIN

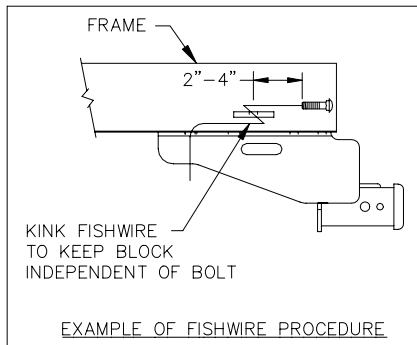
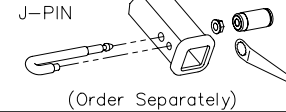

NOTE: FIVE (5) INSTALLATION OPTIONS ARE POSSIBLE DEPENDING ON VEHICLE CONFIGURATION.

REFER TO SHEET 2 FOR FIGURES 2, 3, 4 AND 5.

1. REMOVE ALL BUT A THIN LAYER OF UNDERCOATING FROM ATTACHING SURFACES. ALSO, GRIND OR CHISEL OFF SMALL ALUMINUM RIVET HEADS IF PRESENT ON ATTACHING SURFACES. THIS WILL ENSURE SIDE BRACKETS WILL SIT FLAT AGAINST THE FRAME.

2. OPTION A - SEE FIGURE 2

1996 AND EARLIER VEHICLES EQUIPPED WITH FRAME MOUNTED, CLOSED SIDED, STEEL SKID SHIELD:

- A. REMOVE REAR SKID SHIELD MOUNTING BOLT AND LOOSEN THE FORWARD SKID SHIELD MOUNTING BOLT, EACH SIDE SO THAT THE SKID SHIELD IS LOWERED ABOUT 1/4".

NOTE: DO NOT REMOVE FORWARD MOUNTING BOLT AT THIS TIME OR SKID SHIELD WILL COME OFF.

- B. RAISE HITCH INTO POSITION, PUTTING THE RECEIVER FLANGE BETWEEN THE FRAME AND THE SKID SHIELD.
- C. INSTALL FOUR (4) M12 BOLTS WITH LOCK WASHERS PROVIDED (THE REARMOST ATTACHMENT HAS A HARDENED FLAT WASHER BETWEEN RECEIVER FLANGE AND LOCK WASHER), EACH SIDE AS SHOWN IN FIGURE 1. TIGHTEN FINGER TIGHT.
- D. AT THIS TIME, REMOVE FORWARD SKID SHIELD MOUNTING BOLTS. PLACE TWO (2) 1/2 FLAT WASHERS AS SPACERS BETWEEN FRAME AND SKID SHIELD AND REINSTALL EXISTING M12 FASTENER.

OPTION B - SEE FIGURE 5

1997 AND LATER VEHICLES EQUIPPED WITH FRAME MOUNTED, CLOSED SIDED, STEEL SKID SHIELD:

- A. REMOVE THE REAR SKID SHIELD BOLTS ON EACH SIDE. DRILL HOLE THRU SKID SHIELD BEING CAREFUL NOT TO DAMAGE WELDNUT IN FRAME.
- B. RAISE HITCH INTO POSITION PLACING THE HITCH OVER THE SKID SHIELD FLANGES.
- C. INSTALL FOUR (4) M12 BOLTS WITH CONICAL WASHERS PROVIDED (THE REARMOST ATTACHMENT HAS A HARDENED FLAT WASHER BETWEEN RECEIVER FLANGE AND LOCKWASHER), EACH SIDE AS SHOWN IN FIGURE 5.

OPTION C - SEE FIGURES 2 & 3

VEHICLES EQUIPPED WITH FRAME MOUNTED TOW HOOK ON DRIVER'S SIDE:

- A. REMOVE TOW HOOK AND TOW HOOK BRACKET; RETURN COMPONENTS TO VEHICLE OWNER. MOUNT DRIVER'S SIDE OF RECEIVER USING M12 BOLTS AS SHOWN IN FIGURE 1. MOUNT PASSENGER SIDE OF RECEIVER AS SHOWN IN FIGURE 3.

OPTION D - SEE FIGURE 3

VEHICLES NOT EQUIPPED WITH FRAME MOUNTED, CLOSED SIDED, STEEL SKID SHIELD OR FRAME MOUNTED TOW HOOK:

- A. FISHWIRE 1/4 X 1-1/2 X 2 BLOCKS (1277 & 3719) AND 1/2 X 1-3/4 GR5 CARRIAGE BOLTS THROUGH END OF FRAME AND INTO EXISTING HOLES. RAISE HITCH INTO POSITION AND ATTACH PER FIG. 3.

OPTION E - SEE FIGURE 4

VEHICLES WITH PASSENGER SIDE EXHAUST HANGER STUDS:

- A. REMOVE (2) NUTS FROM EXHAUST HANGER. RUBBER HANGER IN FRONT OF REAR AXLE CAN BE DETACHED TO ALLOW EXHAUST PIPE TO DROP FURTHER.
- B. INSTALL HITCH USING M12 X 40mm BOLTS TO EXISTING WELD NUTS OR 1/2-13 BOLTS WITH BLOCKS TO OPEN HOLES AS SHOWN.
- C. ATTACH EXHAUST HANGER TO STUDS WITH ORIGINAL NUTS.

NOTE: FISHWIRE BLOCKS THROUGH END OF FRAME IN ORIENTATION SHOWN IN FIGURE 4. REMOVAL OF BUMPER (4 BOLTS PER SIDE) MAY EASE FISHWIRING PROCESS.

3. INSTALL ALL REMAINING FASTENERS AS SHOWN.

TIGHTEN ALL 1/2 GR5 FASTENERS TO 75 LB.-FT.

TIGHTEN 1/2" HANDLE NUT TO 50 LB.-FT.

TIGHTEN ALL M12 CL 8.8 FASTENERS TO 68 LB.-FT.

THIS PRODUCT COMPLIES WITH SAFETY SPECIFICATIONS AND REQUIREMENTS FOR CONNECTING DEVICES AND TOWING SYSTEMS OF THE STATE OF NEW YORK AND V.E.S.C. REGULATION V-5.

APPROX WEIGHT (LB.)	FASTENER KIT
35.5	01130-878

NOTE: Check hitch frequently, making sure all fasteners and ball are properly tightened. If hitch is removed, plug all holes in trunk pan or other body panels to prevent entry of water and exhaust fumes. A hitch or ball which has been damaged should be removed and replaced. Observe safety precautions when working beneath a vehicle and wear eye protection. Follow car maker's specs for maximum trailer weight and tongue weight. Do not cut access or attachment holes with a torch.

TOWING PRODUCTS
Plymouth, Michigan

INSTALLATION INSTRUCTIONS

VEHICLE	HITCH NO.
JEEP CHEROKEE	75054
JEEP WAGONEER (DOWNSIZED MODEL)	33002

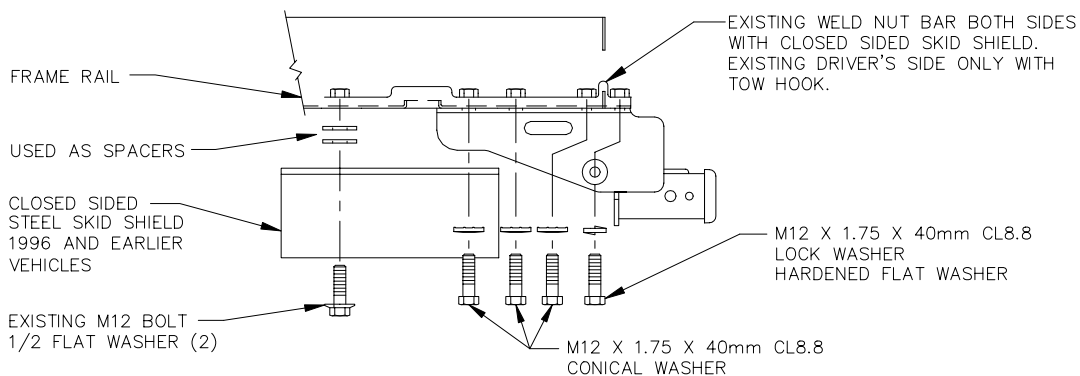

FIGURE 2
OPTION A
OPTION B DRIVER'S SIDE ONLY

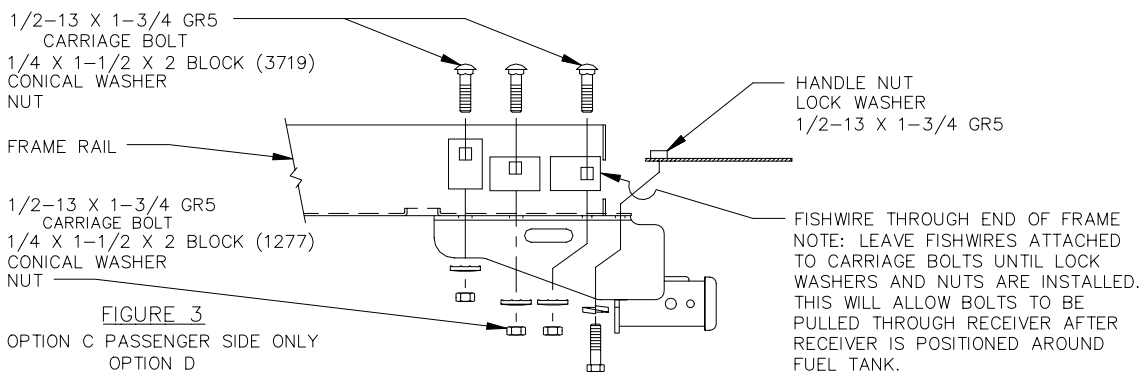

FIGURE 3
OPTION C PASSENGER SIDE ONLY
OPTION D

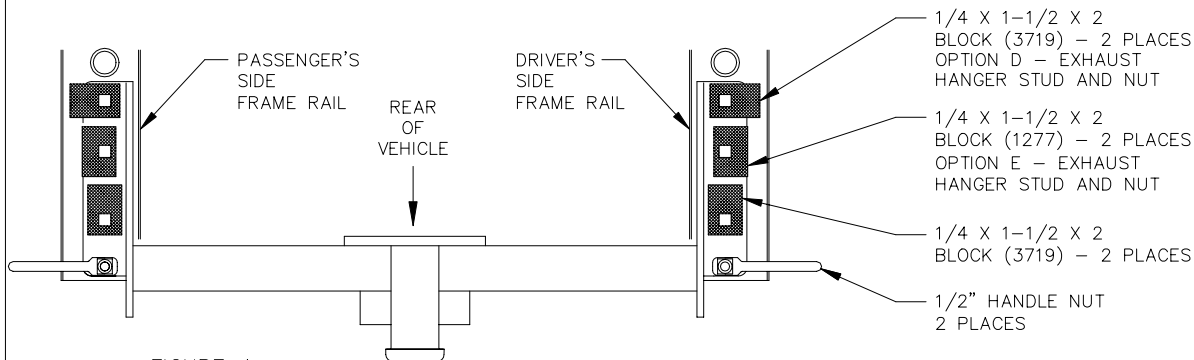

FIGURE 4
VIEWED FROM UNDER VEHICLE LOOKING UP

NOTE: PROPER ORIENTATION OF BLOCKS IS NECESSARY TO INSURE FASTENER ALIGNMENT

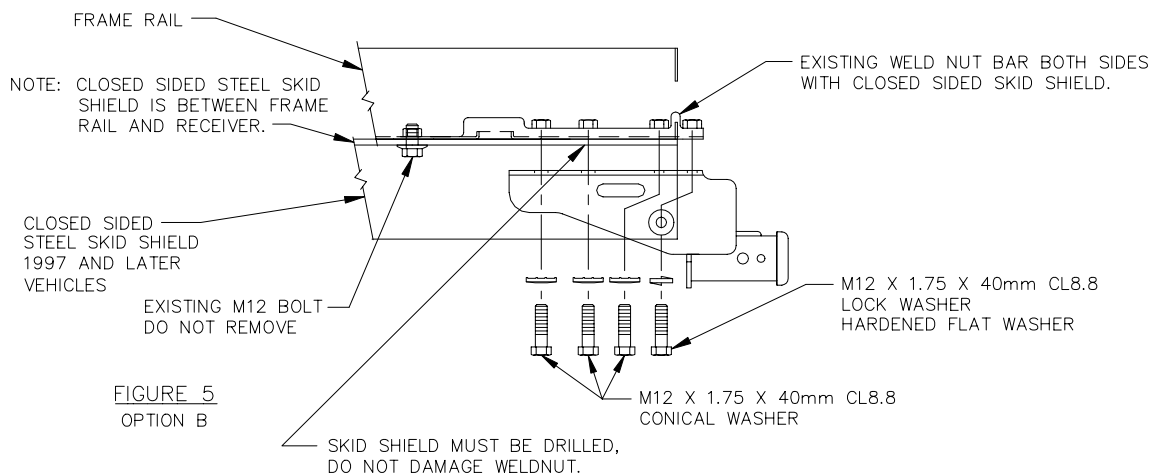

FIGURE 5
OPTION B

APPROX WEIGHT (LB.)	FASTENER KIT
35.5	01130-878

NOTE: Check hitch frequently, making sure all fasteners and ball are properly tightened. If hitch is removed, plug all holes in trunk pan or other body panels to prevent entry of water and exhaust fumes. A hitch or ball which has been damaged should be removed and replaced. Observe safety precautions when working beneath a vehicle and wear eye protection. Follow car maker's specs for maximum trailer weight and tongue weight. Do not cut access or attachment holes with a torch.