

#014653, 014654

6.5" Long Arm Suspension System

1987-2001 Jeep Cherokee XJ

(4.0L I6/Auto Trans.)



READ AND UNDERSTAND ALL INSTRUCTIONS AND WARNINGS PRIOR TO INSTALLATION OF SYSTEM AND OPERATION OF VEHICLE.

SAFETY WARNING

BDS Suspension Co. recommends this system be installed by a professional technician. In addition to these instructions, professional knowledge of disassembly/ reassembly procedures and post installation checks must be known.

PRODUCT SAFETY WARNING

Certain BDS Suspension products are intended to improve off-road performance. Modifying your vehicle for off-road use may result in the vehicle handling differently than a factory equipped vehicle. Extreme care must be used to prevent loss of control or vehicle rollover. Failure to drive your modified vehicle safely may result in serious injury or death. BDS Suspension Co. does not recommend the combined use of suspension lifts, body lifts, or other lifting devices.

You should never operate your modified vehicle under the influence of alcohol or drugs. Always drive your modified vehicle at reduced speeds to ensure your ability to control your vehicle under all driving conditions. Always wear your seat belt.

PRE-INSTALLATION NOTES

1. Special literature required: OE Service Manual for model/year of vehicle. Refer to manual for proper disassembly/reassembly procedures of OE and related components.
2. Adhere to recommendations when replacement fasteners, retainers and keepers are called out in the OE manual.
3. Larger rim and tire combinations may increase leverage on suspension, steering, and related components. When selecting combinations larger than OE, consider the additional stress you could be inducing on the OE and related components.

4. Post suspension system vehicles may experience drive line vibrations. Angles may require tuning, slider on shaft may require replacement, shafts may need to be lengthened or trued, and U-joints may need to be replaced.
5. Secure and properly block vehicle prior to installation of BDS Suspension components. Always wear safety glasses when using power tools.
6. If installation is to be performed without a hoist, BDS Suspension Co. recommends rear alterations first.
7. Due to payload options and initial ride height variances, the amount of lift is a base figure. Final ride height dimensions may vary in accordance to original vehicle attitude. Always measure the attitude prior to beginning installation.

POST-INSTALLATION WARNINGS

1. Check all fasteners for proper torque. Check to ensure for adequate clearance between all rotating, mobile, fixed, and heated members. Verify clearance between exhaust and brake lines, fuel lines, fuel tank, floor boards and wiring harness. Check steering gear for clearance. Test and inspect brake system.
2. Perform steering sweep to ensure front brake hoses have adequate slack and do not contact any rotating, mobile or heated members. Inspect rear brake hoses at full extension for adequate slack. Failure to perform hose check/ replacement may result in component failure. Longer replacement hoses, if needed can be purchased from a local parts supplier.
3. Perform head light check and adjustment.
4. Re-torque all fasteners after 500 miles. Always inspect fasteners and components during routine servicing.

102 S. Michigan Avenue • Coldwater, MI 49036
517-279-2135 • www.bds-suspension.com

PARTS LIST

FRONT

*Qty in () for 124654 only

Part #	Qty*	Description
034652	2	Coil Springs
084601R	1	Pitman Arm
01370	1	Long Arm Crossmember
715	1	Bolt Pack
01371	1	Side Support Plate (drv)
01372	1	Side Support Plate (pass)
01377	1	Nut Tab (drv)
01378	1	Nut Tab (pass)
22-1	2	Crush Sleeve
01373	2	Upper Control Arm
01374	2	Upper Control Arm End (assembled)
36270	2	1" Jam Nut
01375	2	Lower Control Arm
01383	2	Lower Control Arm Flex End (assembled)
01468	(2)	Lower Control Arm End
36274	2	1-1/4" Jam Nut
3523RB	8(4)	Lower Control Arm Bushing
61-1	4(2)	0.875 x 0.156 x 2.620
60107	6	Grease Zerk
01343	1	Front Track Bar
M02888RB	2	Track Bar Bushing
51792-1	1	Track Bar Sleeve
ES3095R	1	Tie Rod End
N116-18J	1	Jam Nut
01543	1	Stabilizer Relocation Bracket
3396	2	Front Bump Stop Spacer
B384G2	2	3/8" x 4" Thread Cutting Bolt
01300	2	Disconnect End (assembled)
01302	2	Disconnect Stud
01303	2	Sway Bar Link
SB58	2	Bushing
45313	2	0.625 x 0.109 x 1.375 Sleeve
01325	2	Sway Bar Link Bracket
718	1	Bolt Pack
01308	2	Shock Stem Eliminator
906	1	Bolt Pack
3529	2	Bump Stop (1987-1996 Only)
3528	2	Bump Stop (1997-2001 Only)
22510	2	Front Brake Line
5188	2	Brake Line Clip
B06103C	2	Brake Line L Bracket
CCW-03-050	4	Crush Washer
099000	3	Zip Tie

REAR

Part #	Qty	Description
01350	2	Bar Pin Eliminator
322	1	Bolt Pack
22512	1	Rear Brake Line
5188	1	Brake Line Clip
099000	1	Zip Tie
01358	2	XJ Rear Shackle

51-1	2	0.750 x 0.095 x 3.140 Sleeve
52-1	4	0.750 x 0.095 x 2.750 Sleeve
M02402RB	4	XJ Spring Bushing (small eye)
M02403RB	4	XJ Spring Bushing (large eye)
M02400RB	4	XJ Shackle Bushing
516	2	Straight Grease Zerk
	4	U-bolts, High Nuts and Washers

BOLT PACK 322

Qty	Description
2	1/2"-13 x 2-1/2" bolt grade 5
2	1/2"-13 prevailing torque nut
4	1/2" SAE flat washer

BOLT PACK 715

Qty	Description
2	9/16"-12 x 4-1/2" bolt
2	9/16"-12 prevailing torque nut
4	9/16" SAE flat washer
2	7/16" SAE flat washer
2	7/16"-14 x 3-1/2" bolt
2	10mm-1.50 x 80mm bolt
4	10mm-1.50 x 40mm bol
2	10mm-1.50 x 30mm bolt
2	10mm-1.50 prevailing torque nut
6	3/8" heavy-duty oversized flat washe
16	3/8" USS flat washer
2	3/8"-16 x 1-1/2" self-tapping bol
2	7/16"-14 x 4-1/2" bolt
2	7/16" prevailing torque nut
2	7/16"-14 x 1-1/4" bolt
2	#12 x 3/4" self-drilling hex head screw
2	Wire Clamp
1	Mountable nylon cable tie
1	1/8" x 1-1/4" cotter pin

BOLT PACK 718

Qty	Description
2	1/2"-20 prevailing torque nut
4	1/2" SAE flat washer
2	1/2"-20 jam nut
2	3/8"-16 x 2-1/2" bolt
2	3/8"-16 prevailing torque nut
4	3/8" SAE flat washer
2	7/16"-14 x 1-1/2" bol
2	7/16"-14 prevailing torque nu
2	7/16" SAE flat washe
2	7/16" USS flat washer
2	#10-16 x 5/8" self-drilling screw

BOLT PACK 906

Qty	Description
2	3/4"-10 standard hex nut
2	3/4" SAE flat washer
2	3/4" lock washer
2	1/2"-13 x 2-1/2" bolt
2	1/2"-13 prevailing torque nut
4	1/2" SAE flat washer

GLOSSARY OF TERMS

- OE** : Original Equipment
SAE washer : Small OD, tight fit to bolt of same size
USS washer : Larger OD than SAE, loose fit on bolt of same size
ft-lbs : Foot Pounds - standard torque units

INSTALLATION INSTRUCTIONS

Note: This suspension system is design for use with 4.0 L 6 cylinder engine/automatic transmission equipped vehicles only. With this setup the transmission crossmembers will be positioned approximately 14" from the back of the OE lower control arm pocket. This dimension can be checked to ensure the proper fitment of this suspension system on your vehicle.

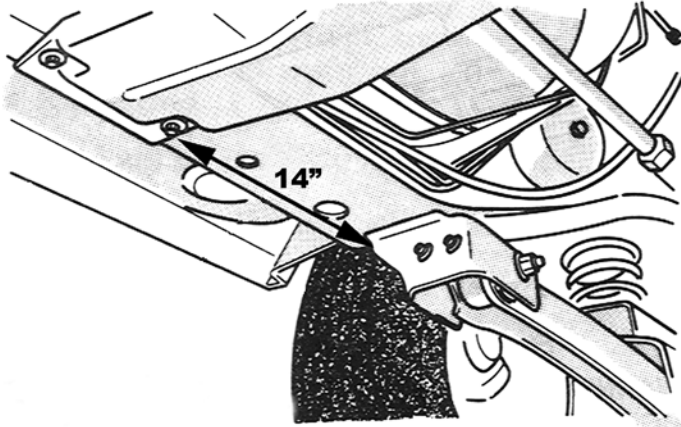

FRONT INSTALLATION

1. Measure and record the distance from the center of the wheel to the bottom of the fender opening:
LF _____ RF _____ RR _____ LR _____
2. Park the vehicle on a clean, level surface and block the rear wheels for safety.
3. Safely raise the front of the vehicle and support with jack stands under the frame rails.
4. Remove the front wheels.
5. Locate the plastic retaining clip on the inside of the driver's side uni-body frame rail (Fig 1). This clip will be holding 4 lines/hoses. Remove the lines/hoses from the clip and remove the clip from the body.

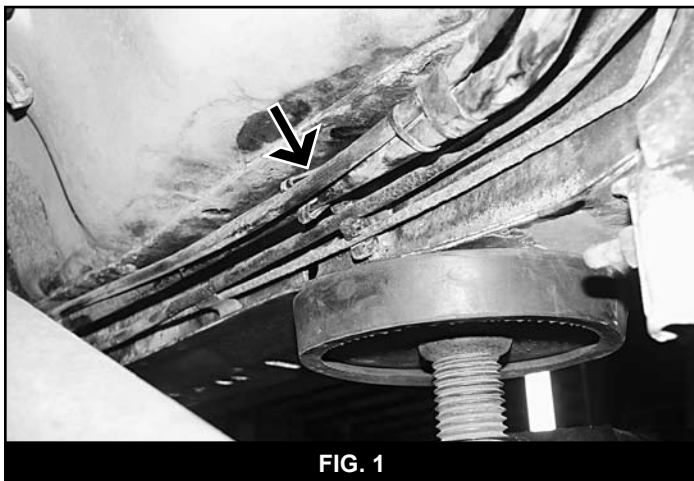

FIG. 1

6. The two steel lines (fuel and brake) will be reattached with the provided clips and self-drilling screws. Disconnecting the front drive shaft from the differential will make this easier but is not necessary. The remaining plastic lines will be fastened to the new crossmember after it is installed.
7. Locate the hole in the frame where the original plastic retaining clip was installed. Install the brake hard line to the frame with the provided clip and self-drilling screw just ahead (1/2" max) of the existing hole in the frame (Fig 2). Position the line up against the floor with the clip mounting tab pointing down. Carefully reform the brake line as needed. Tighten screw securely.
8. Attach the fuel line in the same manner as the brake line. Position the clip directly below the brake line clip with the mounting tab pointing up (Fig 2). This will make the fuel line run low, close to the uni-body pinch weld. **Note:** These line locations provide clearance for the new upper control arm mounting bolt.

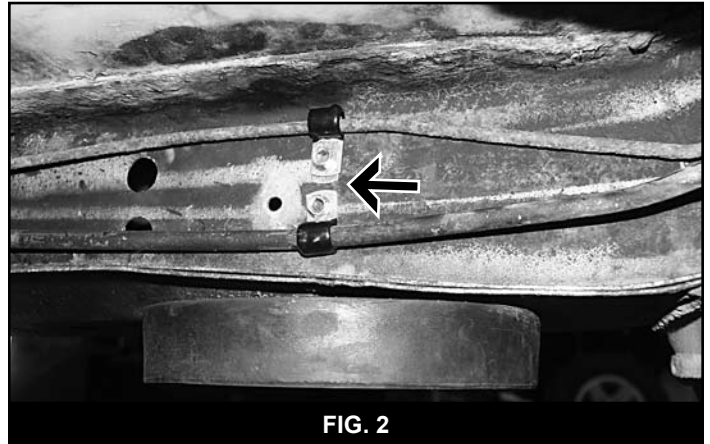

FIG. 2

9. Remove the four transmission mount nuts from the transmission crossmember (Fig 3). Retain hardware.



FIG. 3

10. With a hydraulic jack, lift the transfer case/transmission assembly just enough to relieve pressure from the transmission crossmember.

11. Remove the nuts/bolts retaining the crossmember to the frame and remove the crossmember from the vehicle (Fig 4). **Note:** If equipped with a factory installed transfer case skid plate, remove that as well (Fig 5). It will not be reused.

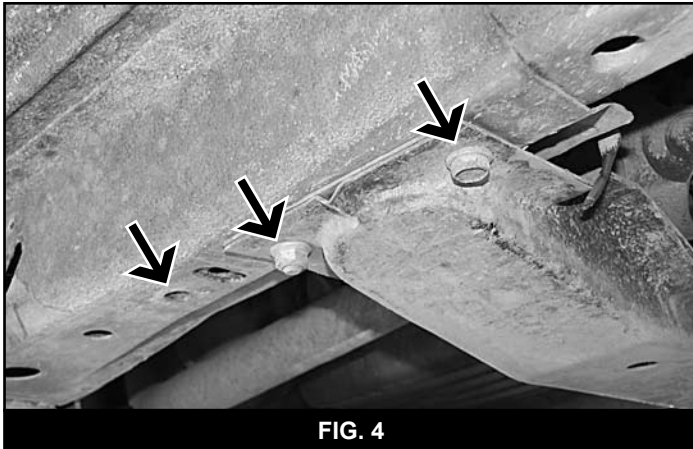

FIG. 4

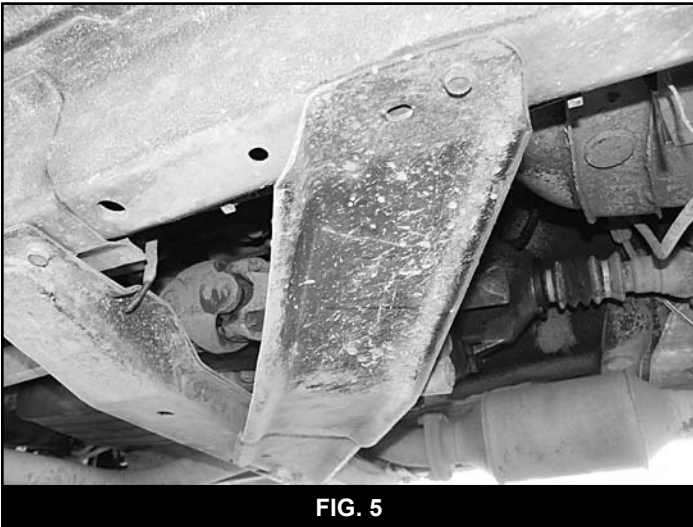

FIG. 5

12. Some models may use a combination of threaded studs/nuts and bolts to fasten the OE crossmember (Fig 4). If this is the case, the threaded studs must be removed. The studs can be removed by either clamping vise grips on it, using the double nut method or tack welding a nut to the stud and using a wrench to remove it.
13. Locate the third threaded hole in the uni-body rails just ahead of the two that were used to mount the OE crossmember (Fig 4). Ensure that the threads are clean of dirt and rust. These holes will be used to mount the new crossmember in conjunction with the original two holes (per side).
14. With the help of an assistant, place the crossmember (01370) up to the uni-body and align the front threaded hole in the body with the front mounting hole in the crossmember. Loosely attach the crossmember to the frame with a 10mm x 30mm bolt and 3/8" USS washer (BP 715) in the second hole from the front of the crossmember on each side of the vehicle (Fig 6). **Note:** Make sure that the remaining loose plastic lines on the driver's side are to the inside of the upper control arm mount on the new crossmember.

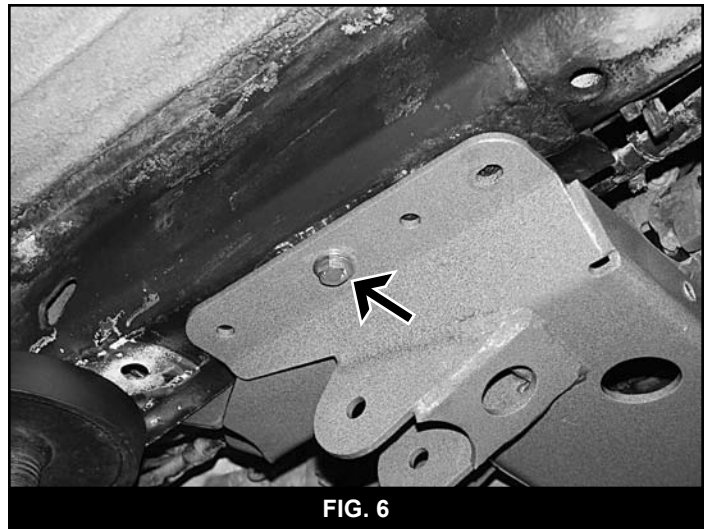

FIG. 6

15. Thread a 10mm x 40mm bolt and 3/8" oversized washer (BP 715) in the front hole on each side of the crossmember just a couple of turns to help square it to the frame and snug the 10mm x 30mm bolt so the crossmember is setting tight to the bottom of the frame. Remove the front 10mm x 40mm bolt and washer.
16. Locate the provided crossmember side support plates (01371, 01372). These parts are driver's and passenger's side specific. Identify the correct side by matching the large relieve in the brackets to the existing bolt holding the crossmember. The relief in the bracket will clear the bolt head.
17. Attach the side support plate so that they "sandwich" the crossmember between themselves and the frame (Fig 7). Attach the brackets with 10mm x 40mm bolts and 3/8" oversized washers (BP 715) in the forward-most and rearward-most holes in the side plates/crossmember. Ensure that the side plates are flush against the side of the frame and snug hardware.

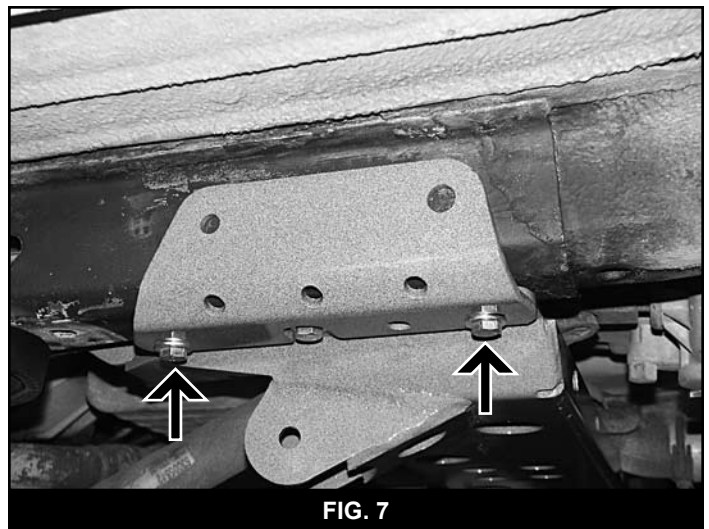

FIG. 7

18. With the side plates in position, mark the center of the two side mounting holes to be drilled. The rear hole is larger than the front hole.
19. With the side support mounting holes marked, remove the two outer 10mm bolts and remove the side supports from the vehicle.

20. Drill a 7/16" hole at the front mark for the side plate. Only drill through the first layer of the frame. Do not drill all the way through the frame.
21. Drill a 7/16" hole at the rear mark for the side plate. Drill outside and inside layers of the frame. Drill straight in the frame as square as possible to the bottom surface of the frame. **CAUTION: BE CERTAIN that all the fuel lines, brake lines, etc are clear from the area being drilled.**
22. With the rear thru-hole drilled to 7/16", go back with a 5/8" drill (or a uni-bit works well too) and drill just the outside layer of the frame. You will now have a 7/16" and a 5/8" hole in the outside of the frame and a single 7/16" hole on the inside (Fig 8).

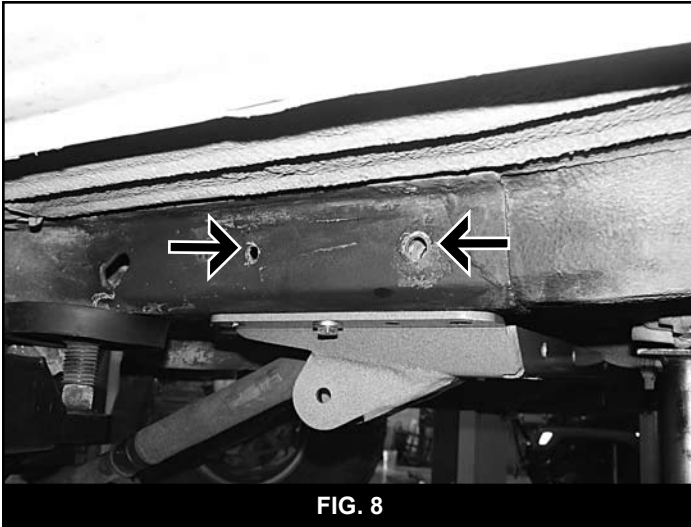

FIG. 8

23. Install the side supports back into position with the same hardware as before. Lightly snug the hardware. Install the provided nut tab (01377, 01378) in the slotted hole in the frame in front of the side support (Fig 9), back to the 7/16" hole drilled earlier (the nut tabs are driver's and passenger's side specific to match the angle of the slot). Loosely fasten the side support with a 7/16" x 1-1/4" bolt and 3/8" USS washer (BP 715) into the nut tab. **Note: Holding the nut tab with vise grip pliers eases installation.**

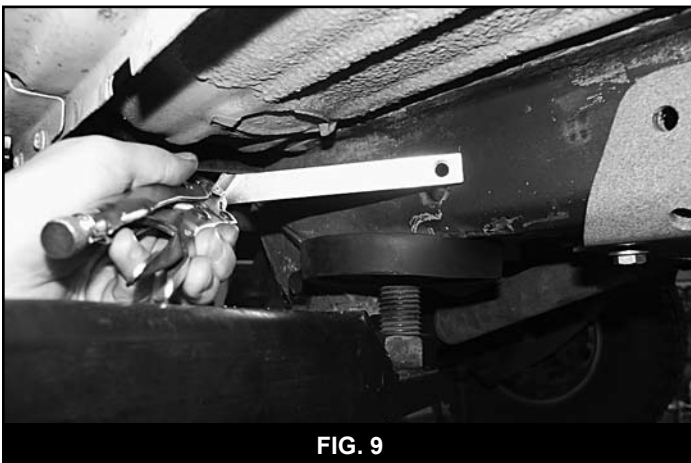

FIG. 9

24. Insert the provided 5/8" x 3-5/8" frame crush sleeve (22-1) in the 5/8" hole just drilled in the frame (Fig 10). Do not push it all the way in at this time.

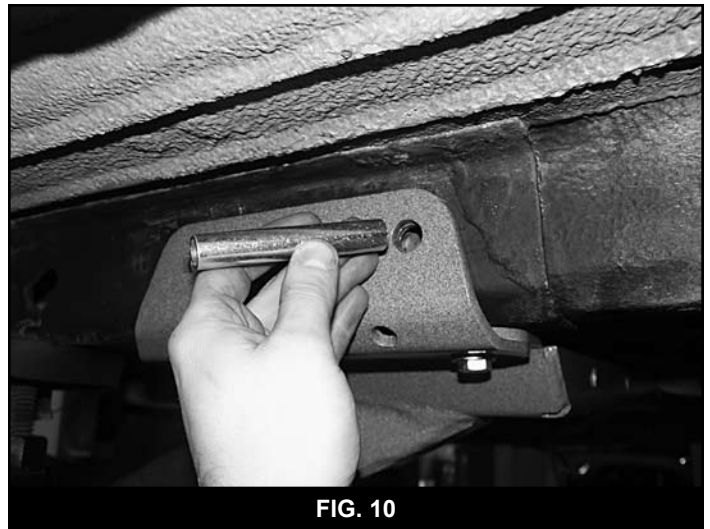

FIG. 10

25. Install a 3/8" USS washer on a 7/16" x 4-1/2" bolt (BP 715) and insert it into the frame crush sleeve. Push the bolt and sleeve all the way into the frame so that the sleeve is against the inside surface of the frame and the bolt is sticking out of the inside 7/16" hole. Fasten the bolt on the inside of the frame with a 3/8" USS washer and 7/16" nut from bolt pack 715 (Fig 11). Leave hardware loose. Ensure that the bolt does not hit the fuel or brake lines. Reform these lines as necessary.



FIG. 11

26. Locate the second hole from the rear of the crossmember (Fig 12 - on both sides). Using the crossmember hole as a guide mark and drill the hole to 5/16".
27. Apply Loctite® to the threads of a 3/8" x 1-1/2" self-tapping bolt and 3/8" oversized washer (BP 715) and install in each of the drilled holes in the bottom of the frame (one on each side). Torque bolt to 30 ft-lbs.
28. Remove each of the 10mm bolts one at a time and apply Loctite® to the threads. Reinstall the bolts and torque to 40 ft-lbs.
29. With all of the main crossmember bolts tight, go back and torque the four 7/16" side plate bolts to 50 ft-lbs.
30. Lower the transmission mount onto the crossmember by aligning the studs in the slots. Fasten the mount to the crossmember with the OE nuts and torque to 25 ft-lbs.

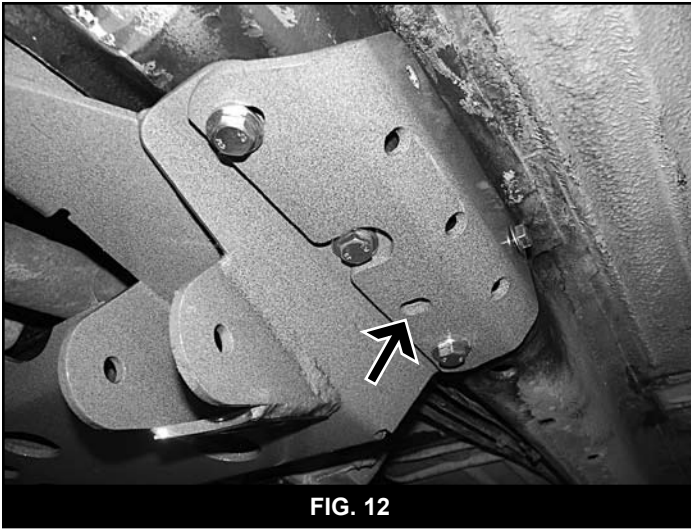

FIG. 12

31. Go back and check the clearance of all the lines running down the driver's side of the frame. Attach the plastic lines to the crossmember with the mount style wire tie (BP 715) by pushing the wire tie into the 1/4" hole in the upper control arm mount and securing the lines (Fig 13).

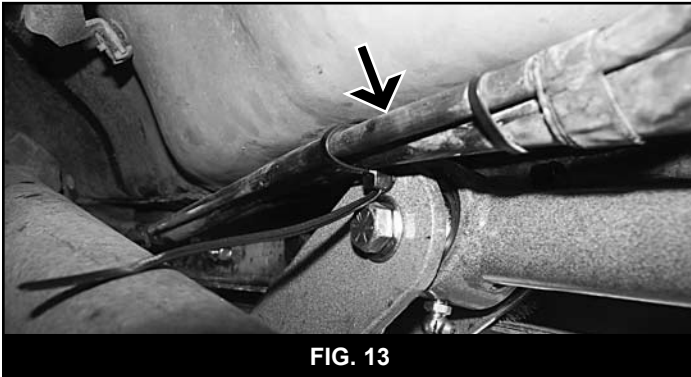

FIG. 13

32. Support the front axle with a hydraulic jack.
33. Remove shocks, retain lower shock hardware.
34. Remove OE sway bar end links and discard (Fig 14).

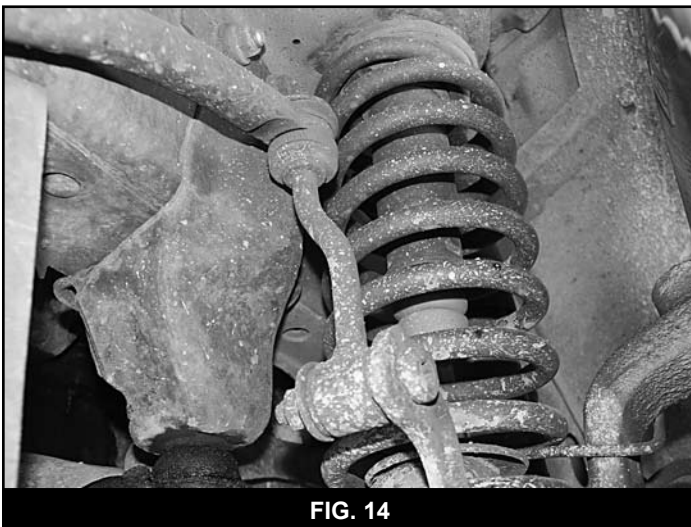

FIG. 14

35. Disconnect the steering stabilizer from the axle and retain hardware. Remove the steering stabilizer from the drag link by removing the nut and dislodging the tapered stud with a pickle fork (Fig 15).

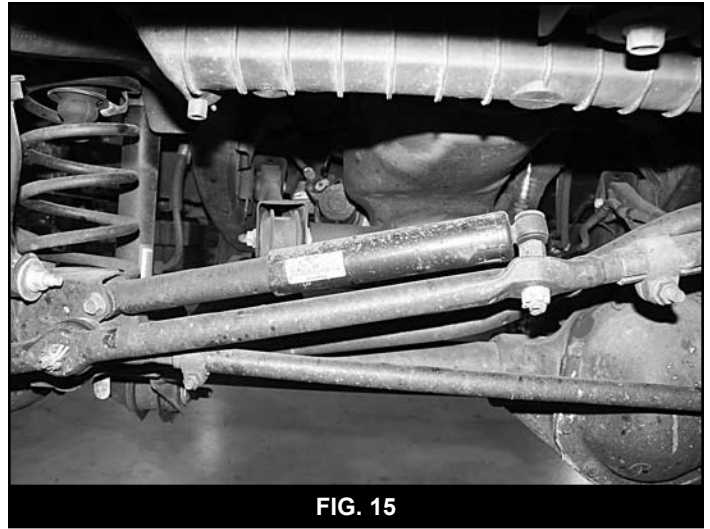

FIG. 15

36. Remove track bar by disconnecting at axle (Fig 16 - retain hardware) and frame mount by removing cotter pin and nut. Use a pickle fork to dislodge the track bar from the frame mount. Disconnect the track bar from the axle. Retain all hardware.

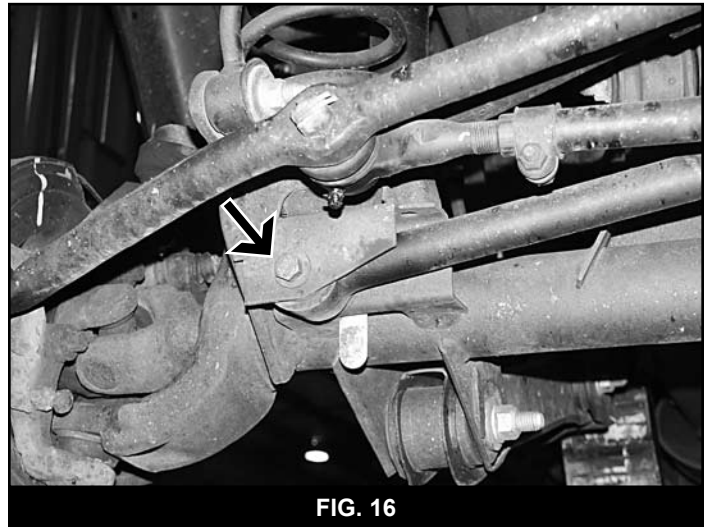

FIG. 16

37. Disconnect centerlink from pitman arm (retain hardware). Use a pickle fork to dislodge the centerlink from the pitman arm.
38. Mark the relationship between the pitman arm and the steering box sector shaft. Remove the pitman arm mounting nut and washer. Retain hardware.
39. Using the appropriate pitman arm puller, remove the OE pitman arm and install the new provided drop pitman arm (084601R) using the alignment marks to ensure it is indexed properly. Fasten with the OE nut and washer and torque to 185 ft-lbs.
40. Remove brake line retaining clips.
41. Remove fasteners holding brake line anchors to frame on driver's and passenger's side.
42. Disconnect passenger's side rubber brake line from metal hard line.
43. Disconnect brake line from caliper and discard crush washers, retain the OE banjo bolt. Ensure old washer is removed from caliper and brake line mounting area.
44. Install new upper brakeline bracket with OE bolt.

45. Mount hard line into new bracket before installing new stainless steel line.
46. Install BDS front brake line (22510) by attaching upper portion first. Tighten securely (Fig 17).

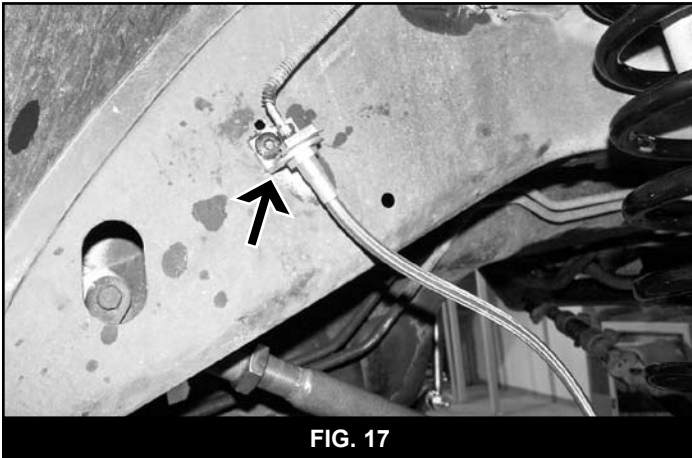

FIG. 17

47. Install lower portion with provided new crush washers and original banjo bolt. **Note:** One washer is required on EACH side of the fitting. Brake line must face up after installation. Torque bolt to 20 ft lbs (Fig 18).

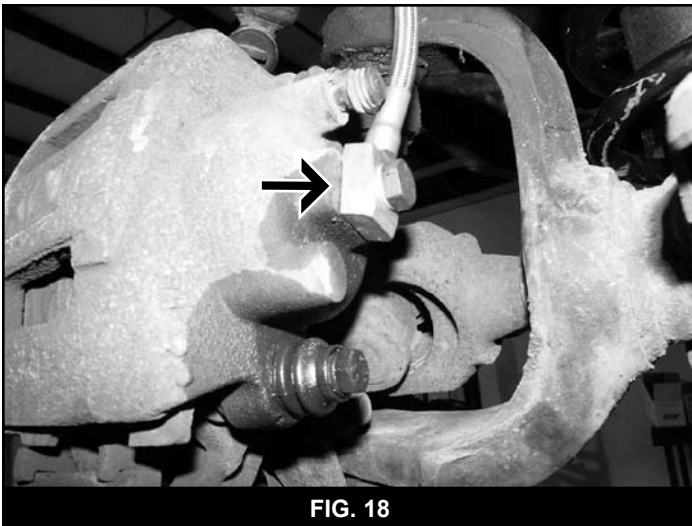

FIG. 18

48. Repeat brake line installation for driver's side.
49. If equipped, remove the lower coil spring retainer clips from the axle (Fig 19). Retain clips and bolts.

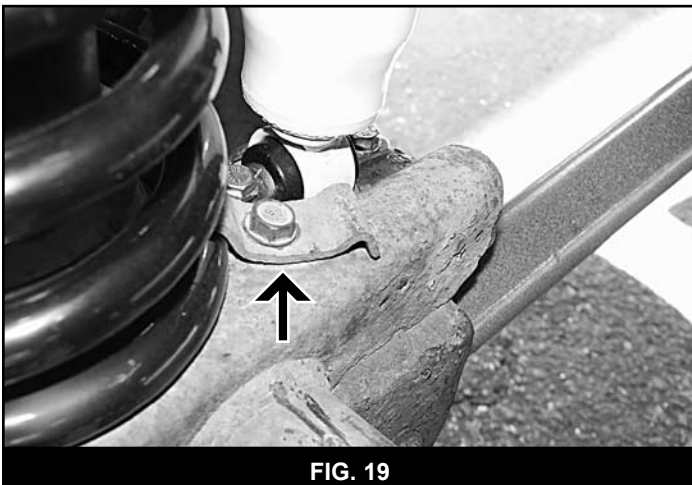

FIG. 19

50. Lower the front axle and remove the front coil springs from the vehicle.
51. Grease and install the provided bushings (3523RB) and sleeves (61-1) in the lower control arms (01375) and adjustable lower control arm ends (01468). **Note:** If using flex end style lower control arms follow same instructions as the standard ends. The flex ends came pre-assembled.
52. Install the provided grease fittings in the lower control arms and control arm ends.
53. Thread the provided jam nut, followed by the adjustable end onto the lower control arm. Adjust the length of the control arm so that it is 32-3/4" from center of eye to center of eye.
54. Thread the provided jam nut, followed by the provided assembled flex end (01374) onto the upper control arm (01373). Install the provided grease fittings in the flex ends (Fig 20). Adjust the length of the control arm so that it is 28-3/8" from center of eye to center of clevis (Slide bolt through clevis end to get this measurement).

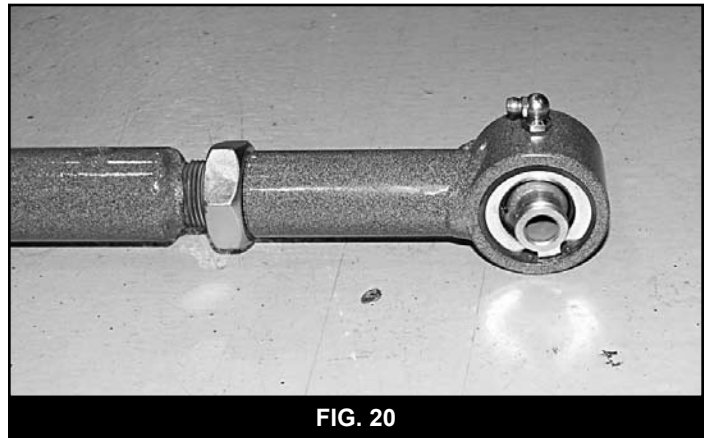

FIG. 20

55. Install the adjustable end of the lower control arms into the new lower control arm pockets in the crossmember (Fig 21). Loosely fasten the arms with 9/16" x 4-1/2" bolts, nuts and 9/16" SAE washers (BP 715). **Note:** Apply a small amount of grease to the faces of the bushings to aid in installation of the control arms.

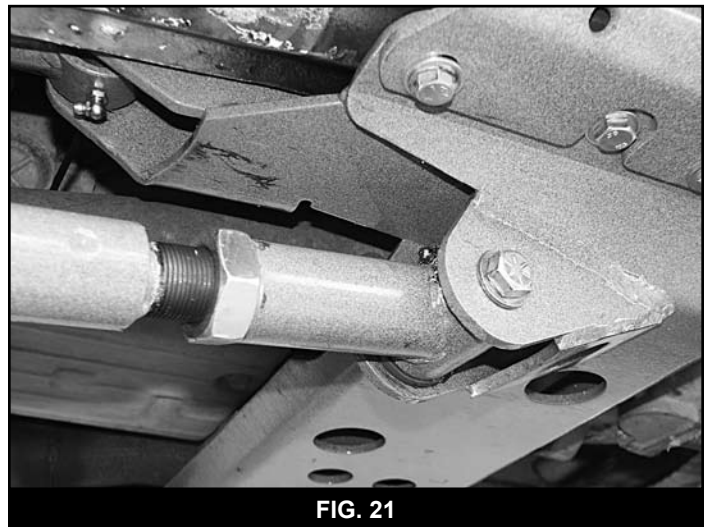

FIG. 21

56. Loosen but do not remove all the OE upper and lower control arm mounting bolts.

57. With the front axle properly supported, remove the lower control arms from the frame and the axle. Retain the axle mount hardware.
58. Install the new lower control arms in the axle mounts and loosely fasten with the OE hardware.
59. Install the new upper control arms into the new upper control arm pockets in the crossmember (Fig 22). Fasten the arms with 7/16" x 3-1/2" bolts and 7/16" SAE washers into the welded nut on the crossmember. Use Loctite® on the bolt threads. **Note:** In some cases it may be necessary to loosen the exhaust to gain clearance for installing the passenger's side control arm bolt. Torque the 7/16" bolts to 50 ft-lbs.

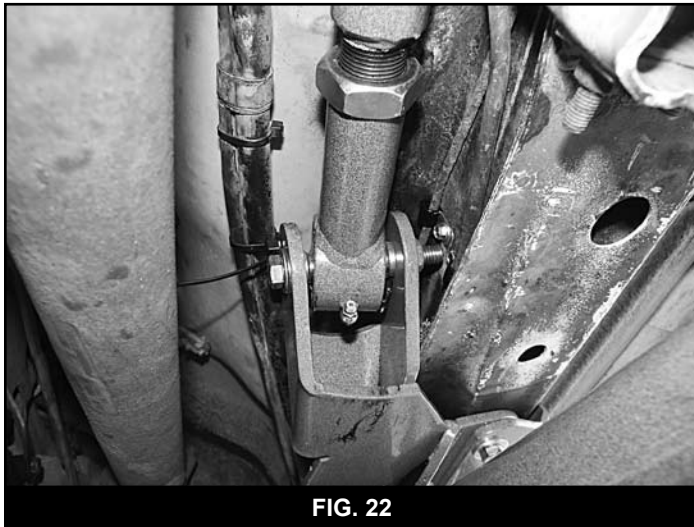

FIG. 22

60. Attach the clevis end of the upper control arms to the front axle mounts (Fig 23). The clevis end will angle in toward the center of the vehicle. Fasten the arms to the axle with 10mm x 80mm bolts, nuts and 3/8" SAE washers (BP 715). Leave hardware loose.

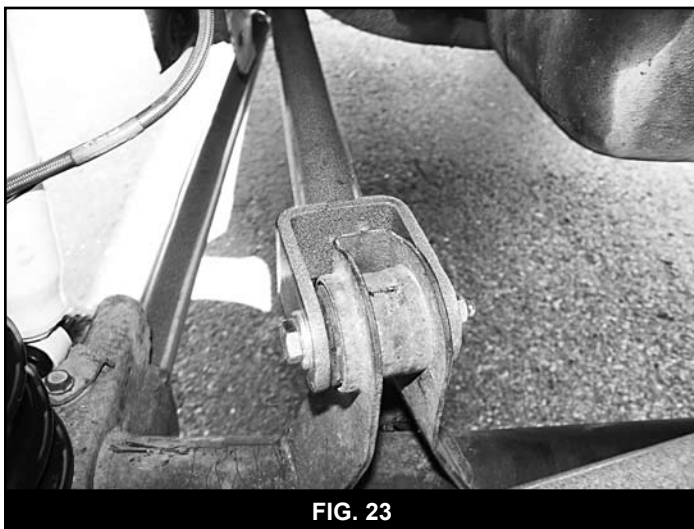

FIG. 23

61. Using a provided zip tie, attach the differential breather tube to the driver's side upper control arm.
62. Locate and drill a 5/16" hole in the center of the front coil spring axle mounts (Fig 24). Use a provided 3/8" x 4" self-tapping bolt to cut the threads for the bump stop extension (3396). Remove the bolt and save for installation of bump extensions later.

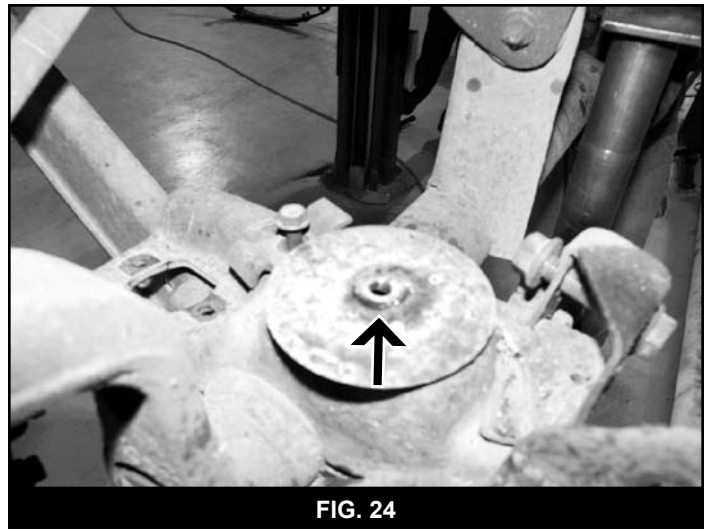

FIG. 24

63. Remove the front OE rubber bump stops and replace with the provided longer ones (3528 or 3529). Apply a small amount of grease to the bump stop and push it into the mounting cup.
64. Install the new BDS coils (034652) with the provided lower bump stop (3396) inside the spring. Rotate the spring until the end is seated correctly in the axle mount.
65. If equipped, install the OE coil retainer clips with the original bolts. Torque to 25 ft-lbs.
66. Attach the bump stop extension with the provided 3/8" x 4" self-tapping bolt and 3/8" USS washer (washers - BP 715). Torque to approximately 30 ft-lbs.
67. Loosely install the provided shock adapter u-brackets (01308) to the front shocks with 1/2" x 2-1/2" bolts, nuts and 1/2" SAE washers (BP 906). Install the shocks in the vehicle with the OE lower hardware and 3/4" nut, 3/4" flat and lock washers (Fig 25). Torque 3/4" nut to 90 ft-lbs, 1/2" hardware to 55 ft-lbs and OE hardware to 25 ft-lbs.



FIG. 25

68. Drill the OE lower sway bar link mount to 1/2" (Fig 26).
69. Install the new lower ball stud (01302) to the OE sway bar link mount with a 1/2" nut and two 1/2" SAE washers (BP 718). The washers mount on each side of the OE mount (Fig 27). The ball mounts toward the inside of the vehicle. Torque stud to 60 ft-lbs.

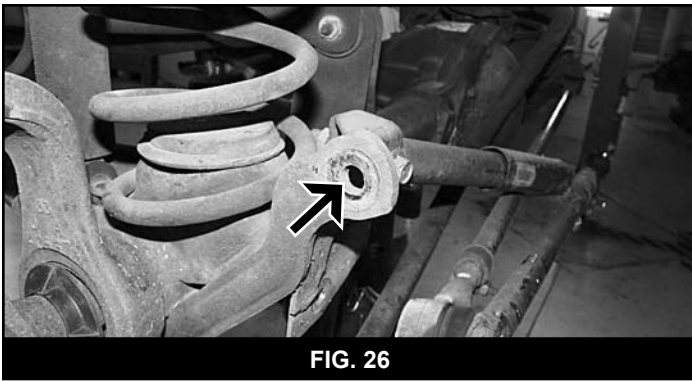

FIG. 26

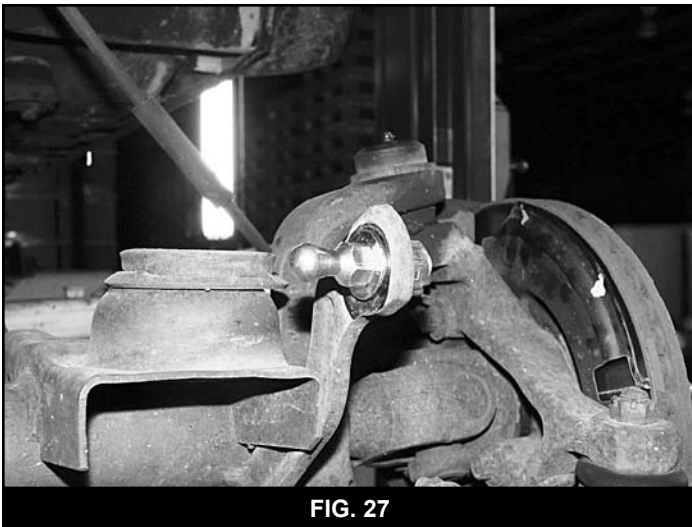

FIG. 27

70. Install the provided upper u-bracket (01325) to the sway bar using the original link mounting hole with a 7/16" x 1-1/2" bolt, nut, 7/16" SAE and 7/16" USS washers (BP 718). Install the bolt up through the u-bracket with an SAE washer into the sway bar. Fasten with the nut and USS washer. Position the bracket so that the thru-holes are parallel with the stud on the axle (Fig 28). Torque to 50 ft-lbs.

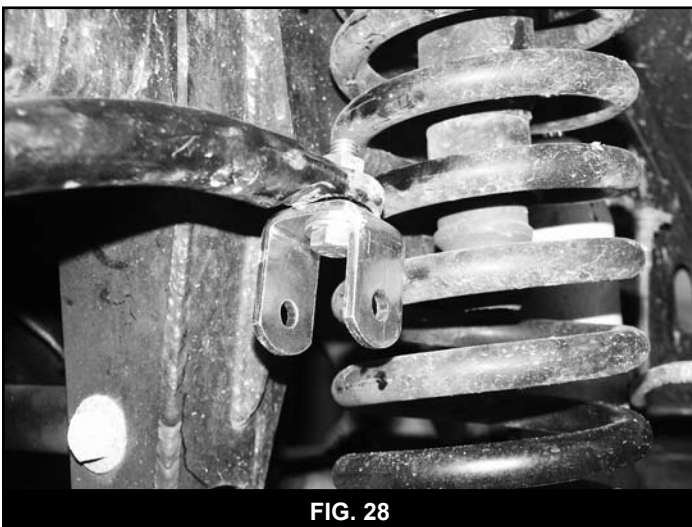

FIG. 28

71. Lightly grease and install the provided hourglass bushings (SB58RB) in the ends of the new sway bar links (01303). Lightly grease and install the provided sleeves (45313) in the bushings.

72. Install the provided 1/2" jam nut (BP 718), then the spring loaded disconnect assembly (01300 assembled) on the threaded end of the new link. Thread the nut and assembly all the way on to the link (Fig 29).

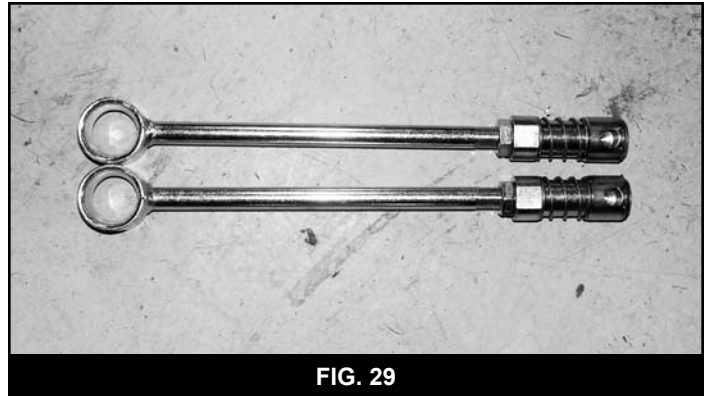

FIG. 29

73. Attach the sway bar link assembly to the upper u-bracket with the provided 3/8" x 2-1/2" bolt, nut and 3/8" SAE washers (BP 718), running from the inside out. Torque bolt to 30 ft-lbs. Leave the sway bar links disconnected at this time.

74. Grease and install the provided track bar bushings (M02888RB) and sleeve (51792) in the new track bar (01343). Thread the provided track bar jam nut (N116-18J) on the track bar end (ES3095R) and thread the end into the bar. Install the provided grease zerk in the track bar end. The exact length will be adjusted at the end of the installation.

75. Install the new track bar assembly to the original steering stabilizer axle mount with the original stabilizer hardware so the track bar runs up toward the OE frame mount (Fig 30). Leave hardware loose. The frame end will be attached at the end of the installation.

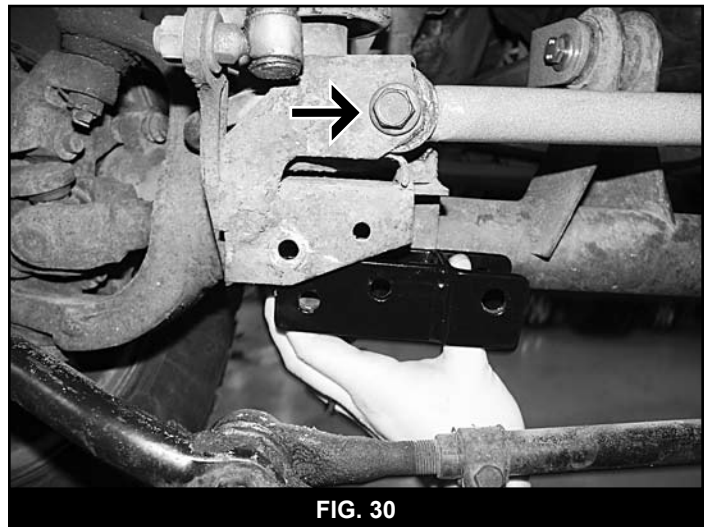

FIG. 30

76. Attach the drag link to the pitman arm with the original castellated nut and new provided cotter pin (BP 715). Torque nut to 50 ft-lbs. Do not loosen the nut to install the cotter pin, only tighten.

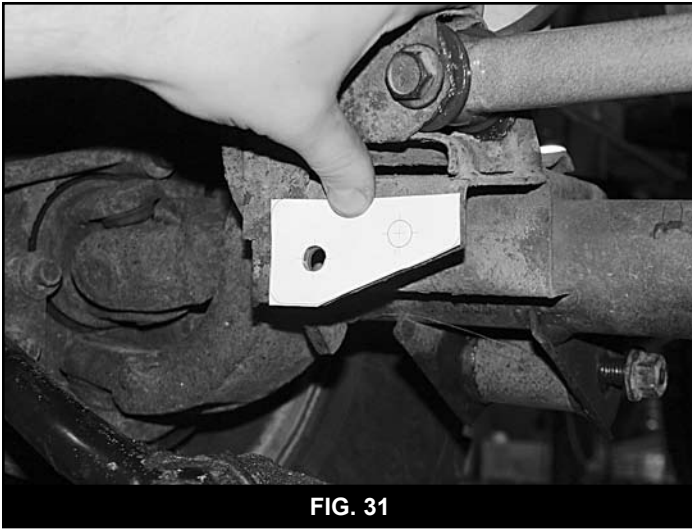

FIG. 31

77. Cut out the stabilizer bracket template at the end of this instruction sheet. Align the template to the original track bar mount on the passenger's side of the axle. The template will match up to the existing hole and the profile (Fig 31). Mark the second hole to be drilled with a center punch. Remove the template and drill hole to 3/8".
78. Install the provided steering stabilizer bracket (01543) in the original track bar mount and fasten with the OE track bar bolt and nut tab (Fig 30). Leave loose.
79. Align the second mounting hole in the bracket with the newly drilled hole and install a 3/8" x 1-1/4" bolt, nut and 3/8" SAE washers (BP 323). Torque 3/8" hardware and OE track bar hardware to 30 ft-lbs. The stabilizer cylinder will be installed when the vehicle is on the ground.
80. Use zip ties to fasten brake lines clear of any rotating or heated components.
81. Install wheels.
82. Remove the jack stands and lower the vehicle to the ground.
83. Bounce the front of the vehicle to settle the suspension. Visually check to see that the front axle is centered under the vehicle. Turn the steering wheel back and forth to help center.
84. Adjust the track bar until the proper length is set so the track bar end will mount into the OE frame bracket. Fasten with the new castellated nut and cotter pin. Torque nut to 50 ft-lbs. Do not loosen the nut to install the cotter pin, only tighten.
85. Torque the track bar axle mount hardware to 60 ft-lbs.
86. Lock off upper and lower control arm jam nuts securely. Ensure the flex ends are square to the pockets before tightening. Torque the lower control arm bolts to 95 ft-lbs. Torque the upper control arm bolts at the axle to 40 ft-lbs.
87. Install the provided bushings and sleeves in the new stabilizer cylinder. The small ID sleeve will go in the rod end of the stabilizer. Attach the body end of the stabilizer to the new stabilizer bracket with a 1/2" x 2-3/4" bolt, nut and 1/2" SAE washers (BP 323). Torque bolt to 60 ft-lbs.

88. Install the provided stabilizer steering bracket (01504) to the stabilizer with a 3/8" x 2-1/2" bolt, nut and 3/8" SAE washers (BP 323). Install the bracket so that the four slotted holes are toward the driver's side. Leave hardware loose.
89. Turn the wheels all the way to the passenger's side. Compress the cylinder to approximate 1/4" from bottoming out. Place the mounting bracket up against the tie rod (Fig 32) and fasten with the provided 5/16" u-bolts, 5/16" nuts and 1/4" USS washers (BP 323). Torque u-bolts to 22 ft-lbs. Torque the 3/8" stabilizer bolt to 30 ft-lbs.

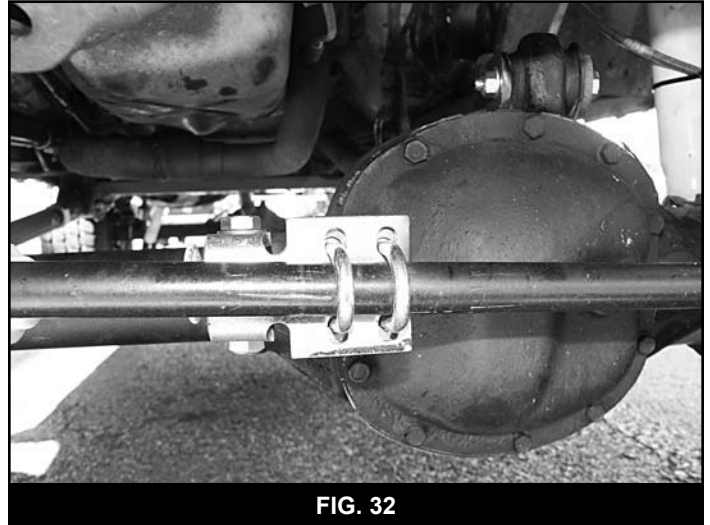

FIG. 32

90. Cycle the steering from lock to lock to ensure proper clearance and adjust as necessary.
91. Ensure the vehicle setting level on the ground. Pull the spring collar up of the disconnect ends and attach them to the ball studs on the axle. Make sure the disconnect end stud is square with the ball stud and tighten the jam nut against the disconnect end. These disconnects allow for 1/2" adjustment (1/2" longer from full-bottomed out).
92. Check the jam nuts to be sure they are securely locked off. Disconnect both end links and fold them up against the sway bar. Clip the provided lanyard/clip assembly around the sway bar/end link and find the best position for mounting the lanyard. This position will vary from vehicle to vehicle. Use your best judgment. Use the provided self-drilling screws to mount the lanyard to the body/frame (Fig 33).
93. With the lanyards installed, reconnect the sway bar links to the axle. The lanyards can be reattached to themselves so that they remain out of the way of moving parts when not in use.

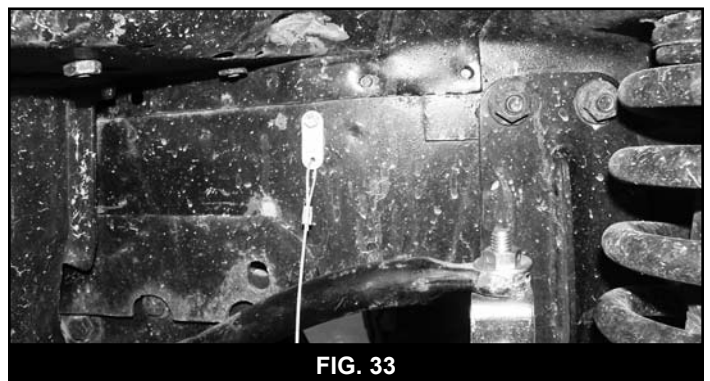

FIG. 33

FRONT LOWER CONTROL ARM POCKETS

Note: This suspension system does not require the removal of the OE lower control arm pockets. Under normal driving conditions and offroad use the new lower control arms will not contact the OE lower control arm pockets. However, heavy impacts (such as jumping) can potentially cause contact between the arms and the pockets. Also, if the front bump stops are not installed per these instructions, contact can occur under compression. Use your best judgment on whether the pockets should be removed or not. These pockets are no longer needed once this install is complete. Some individuals will remove the pockets purely for appearance purposes.

1. Mark a cut line on the two lower control arm pockets that follow the contour of the frame (Fig 34). Using a reciprocating saw or cut-off wheel remove the pocket from the frame. Take care not to cut into the frame.

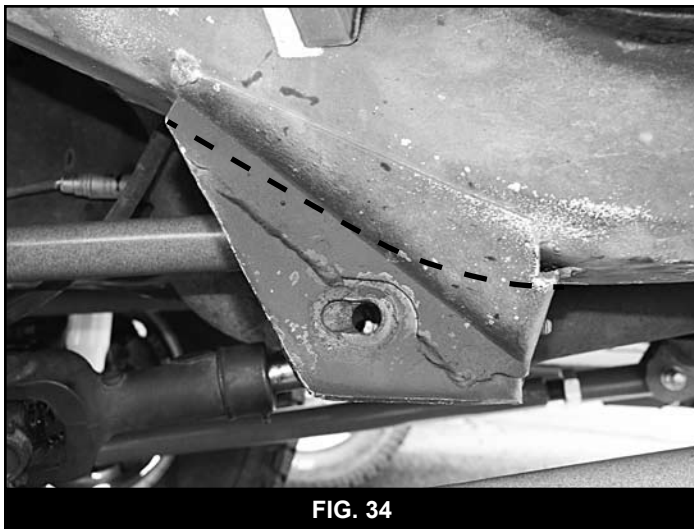

FIG. 34

2. Grind the cut edges smooth. Paint all exposed metal to prevent corrosion.

REAR INSTALLATION

1. Block the front wheels. Safely raise the rear of the vehicle and support with jack stands for safety.
2. Remove wheels.
3. Place a floor jack under the rear axle for support and remove rear shocks, retain OE hardware.
4. Remove sway bar ends from body.
5. Remove retaining clip holding brakeline to driver's side frame.
6. Disconnect rubber brake line from hard line at retaining clip location.
7. Disconnect hardlines from brake line junction block on axle.
8. Unbolt brake line junction block from axle. Retain bolts.
9. Install new BDS rear brake line (22512) in place. Torque to 25 ft-lbs.
10. Reattach axle breather.
11. Install new retaining clip.
12. Apply a small amount of grease to bushing (M02400RB) and install bushing, sleeve (52-1), and grease zerk into the shackle (01358).

13. Grease and install bushings into leaf spring eyes (M02402RB & M02403RB) then install sleeves (52-1 & 51-1).
14. With the rear differential supported remove passenger side spring mounting bolts, u-bolts, shackle, and springs. Save leaf spring and shackle mounting bolts for later installation. **Note:** Once all of the u-bolts are removed, the sway bar can be disconnected from the frame and removed from the vehicle. It will not be reused.
15. Locate the bumper bolt that is protruding into the shackle pocket (Fig 35). This bolt will contact the new larger shackle through suspension travel. The bolt can either be cut off flush with the welded nut on the body or removed.

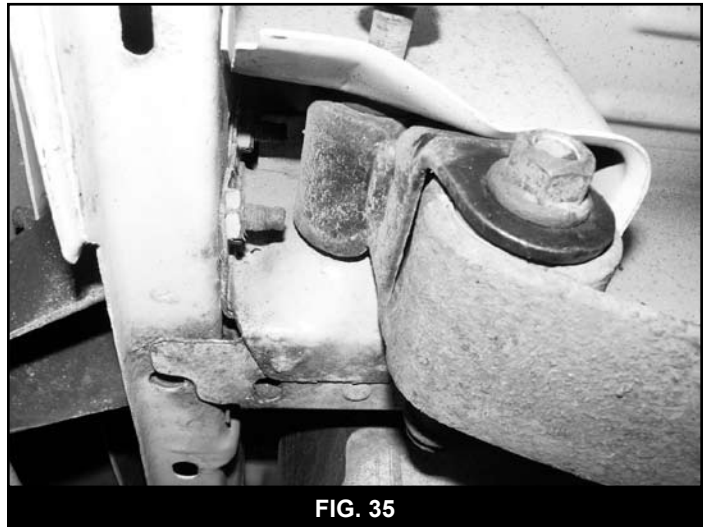

FIG. 35

16. Install the new spring and shackle in the OE locations with the original hardware. Leave the spring and shackle bolts loose at this time. The shackle grease fittings should be toward the front of the vehicle.

Note: The system is designed to be use with a slip yoke eliminator kit and new CV style drive shaft. The shims installed on the leaf springs are set to provide the appropriate drive line angles for most slip yoke/CV driveshaft setups. If additional/different shims are required, they can be purchased separately from BDS.

17. Install new u-bolts and hardware. Snug hardware (Note: Do not torque to specification until vehicle is on the ground.)
18. Repeat for driver's side.

19. Install the provided upper shock bar pin eliminator brackets (01350) with the original upper shock mounting hardware (Fig 36). Torque to 20 ft-lbs

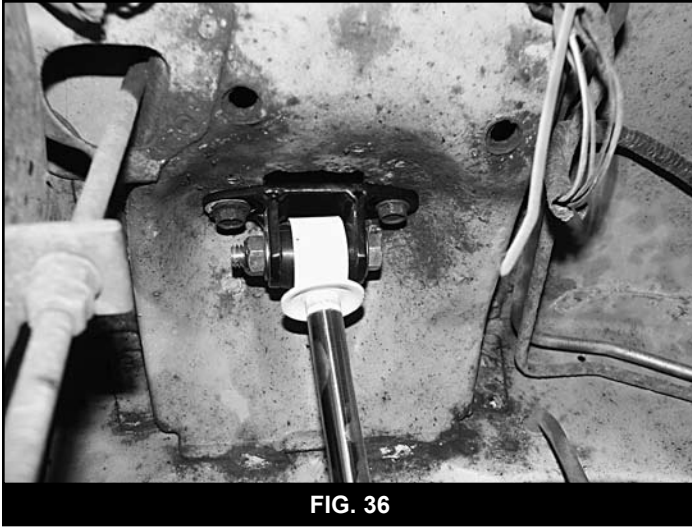

TEMPLATE

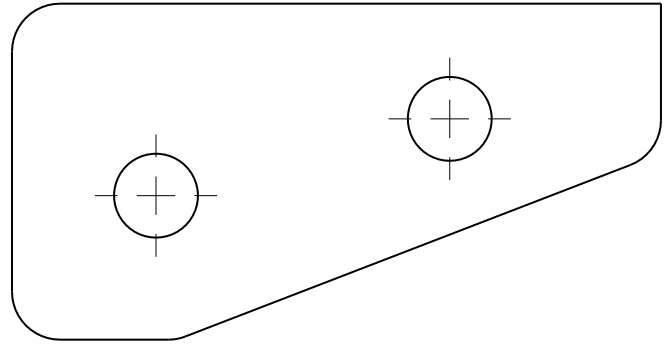

20. Install new shocks with the OE lower nuts and the provided 2-1/2" bolts, nuts and 1/2" SAE washers (BP 322) at the new top mount. Torque shock hardware to 55 ft-lbs.
21. Install wheels.
22. Remove jack stands and lower vehicle to the ground. Bounce vehicle to normalize rear suspension. The shackles will now be in their intended position.
23. Torque shackle and leaf spring bolts to 95 ft-lbs.
24. Torque u-bolts to 75-90 ft-lbs.
25. Bleed brakes starting with the wheel furthest away from master cylinder.
26. Go back through and grease all new greasable components (control arms, track bar, shackles). These components should be serviced regularly and after off-road use.
27. Double-check all fasteners for proper torque.
28. Check all moving parts for clearance.
29. Complete a full radius turning check to ensure that no interference occurs. Adjust front wheel toe-in and center steering wheel.
30. Align headlights.